

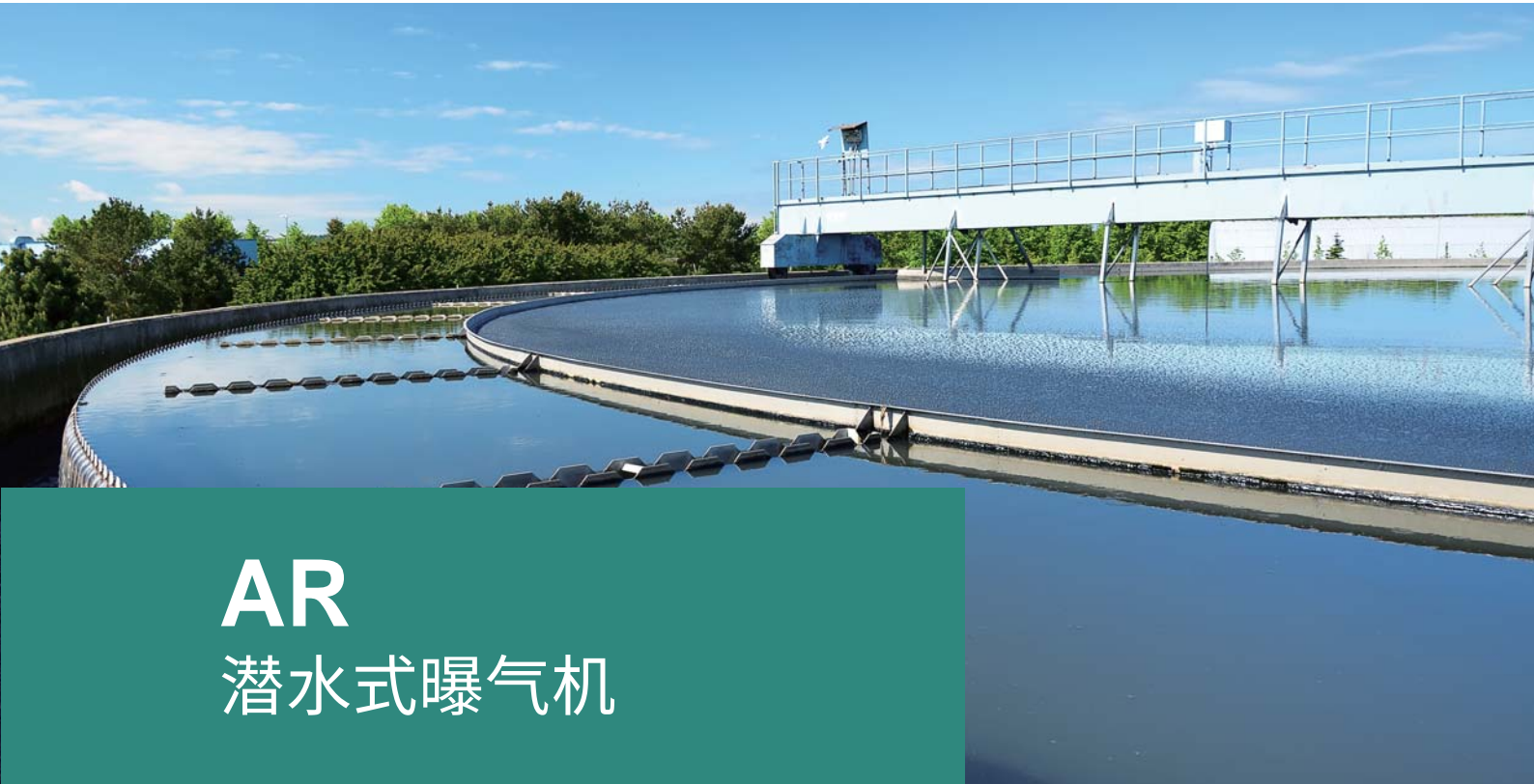

川源(中国)机械有限公司
GSD (China) Co., Ltd.



AR

潜水式曝气机

AR Submersible aerator

AR 潜水式曝气机

AR Submersible aerator

简介 General

由于工业之急速发展，大量的废水也由于工业发达而产生，同时，一般生活污水也大量增加。所有这些已使生活品质深受影响，而生态环境也受到破坏。川源公司有鉴于此，从事研发废水处理设备多年。潜水曝气机及表面曝气机可以更有效地进行多种工业废水处理，使废水的 BOD 及 COD 达标。这些曝气机已广泛地被国内外工业废水和小型生活污水处理工程界采用。

As a result of rapid industrial development, enormous quantity of wastewater were generated, in the meantime large quantities of household waste water were also resulted from our daily lives. All these have affected the living quality and damaged the environmental ecology. For this purpose, GSD has been making every endeavor in researching and developing waste water treatment equipment for years, now GSD produces a series of industrial submersible aerators and surface aerators, which are capable of effectively treating wastewater and enable BOD & COD rate in the wastewater to meet standard. These aerators have been widely used in industrial wastewater treatment plant and small-scale municipal sewage treatment plant inside and outside the country.

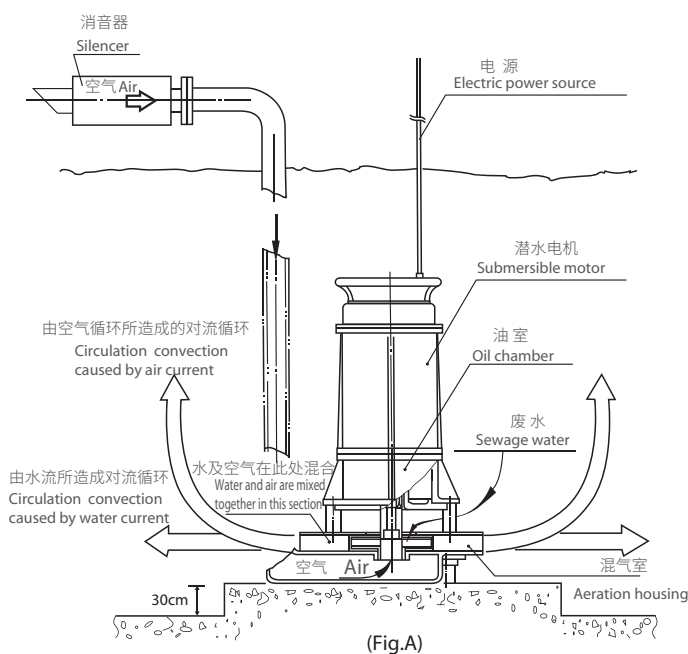

特性 (参照A图)

AR型潜水式曝气机利用马达直接传动叶轮之旋转来产生离心力，使附近的低压吸进水流，同时，叶轮进口处也制造真空以吸入空气，在混气室中，这些空气与水混合之后由离心力作用急速排出。由于水流喷射极强，形成有效的对流循环，而使空气分割成众多细小的气泡。并由于气泡上升缓慢而使大气中之氧气溶解于水中。因为气泡均为细小且不可计数，其表面积很大，这样使每单位马力之传氧率高于其它种类的曝气机。

Characteristics (refer to fig.A)

Submersible aerator-AR utilizes the rotation of the impeller coupled directly to the motor to create a centrifugal force, which makes local low pressure suck in water. Meanwhile the entrance of the Impeller results in vacuum to draw air from atmosphere. Water and air mix in the channel of aeration housing. The air-water-mixture current is discharged speedily by the centrifugal force.

Due to the water spurting extremely strong, make the fluid create convection and circulation effectively. Moreover the air becomes tiny bubbles. On the one hand the bubbles rise slowly, on the other hand the atmosphere oxygen is dissolved in water. Because the bubbles are tiny and numberless, their surface area is large, it makes the oxygen transfer rate per unit BHP higher than other types of aerator.

型号说明 Type description

AR 5 15 -100

AR	进气管直径 (mm)	Air inlet pipe diameter (mm)
5	电机功率 (kW)	Motor power (kW)
15	频率 (Hz)	Frequency: 5: 50Hz
-100	潜水曝气机	Submersible aerator

结构简图 Construction

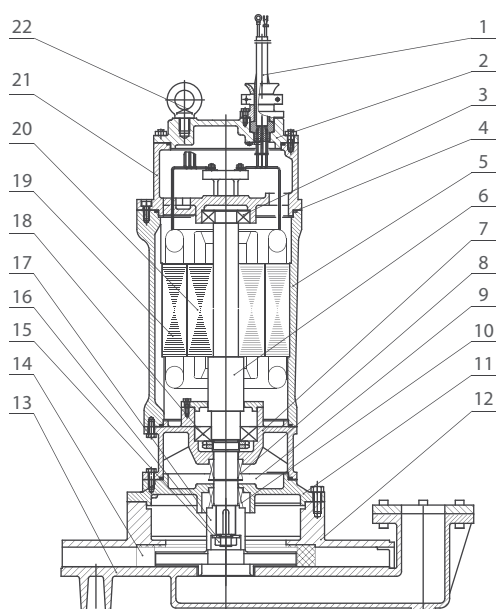

编号 NO.	名称 Name	材质 Material	
		GB	JIS
1	电缆 Cable	2RNCT	2RNCT
2	马达盖 The motor cover	HT200	FC200
3	轴承 Ball bearing	-	-
4	O型圈 O-ring	NBR	NBR
5	电机壳 Motor casing	HT200	FC200
6	主轴 Main shaft	2Cr13	SUS420J1
7	中承座 Bracket	HT200	FC200
8	机械密封 Mechanical seal	C-Al ₂ O ₃	C-Al ₂ O ₃
9	润滑油 Lubricant	ISO VG32	ISO VG32
10	机械密封 Mechanical seal	SiC-SiC	SiC-SiC
11	油箱盖 Oil cover	HT200	FC200
12	混气室 Aeration housing	HT200	FC200
13	混气室底盖 Bottom cover of aeration housing	HT200	FC200
14	入口镶块 Entrance panel board	ZG0Cr18Ni9	SUS304
15	螺母 Screw	A2-70	A2-70
16	垫圈 Gasket	3Cr13	SUS420J2
17	叶轮 Impeller	ZG0Cr18Ni9	SUS304
18	轴承 Ball bearing	-	-
19	定子 Stator	-	-
20	转子 Rotor	-	-
21	电机盖 Motor cover	HT200	FC200
22	吊环 Lifting rings	0Cr18Ni9	SUS304

特点

- 沉水式电机直接驱动，噪音小，效率高。
- 独特的混气室设计，使吸入空气量多，混合效果好，在曝气的同时兼有搅拌作用。
- 采用双层机械轴封，延长电机寿命。
- 双重无堵塞保护：
 - 1.采用高滤孔率的滤网，在保持进气量的同时，可阻挡杂物。
 - 2.增大叶轮与混气室的间距，可避免叶轮卡到异物。
- 可使用导轨，使安装维护方便。

Features

- Submersible motor directly drive, low noise, high efficiency.
- It has unique design for gas mixing chamber whose air intake quantity is big. Air can be mixed well with water. It also has mixing function while aerating.
- Adopt double mechanical seal, can extend useful life of motor.
- Dual protection :
 - 1.Using a high filtration rate of the filter mesh to prevent particles from entering aerator body while maintaining the air input capacity.
 - 2.Enlarge the space between the impeller and the mixing chamber to avoid the impeller being stuck by foreign material.
- Use guide rail to allow pump for easy installation, maintenance & reparation.



性能曲线 Performance curves

空气特性曲线 Air specific curves

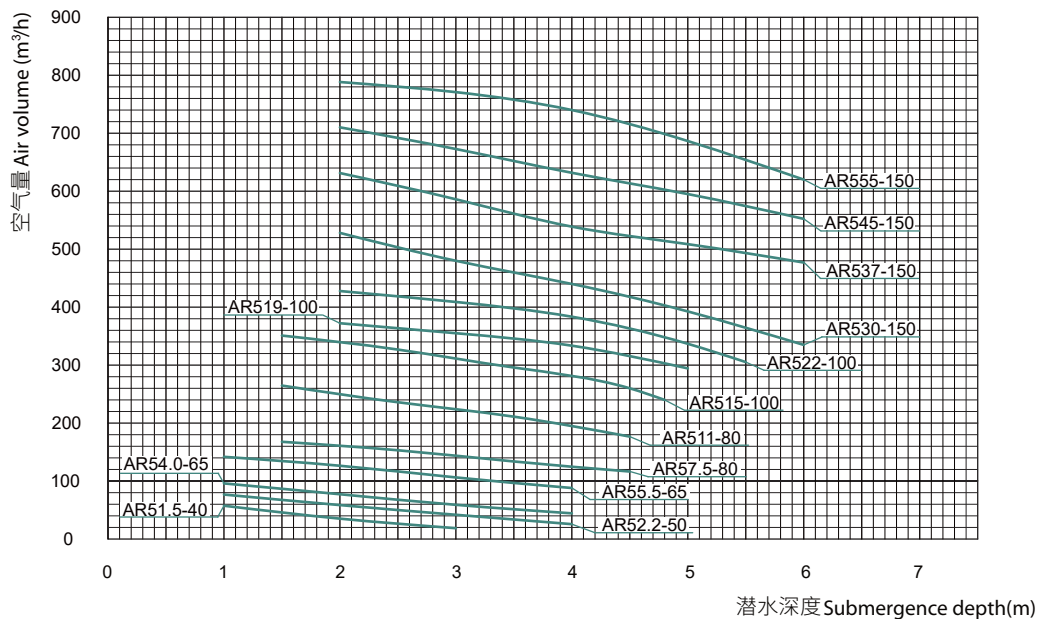

功率特性曲线 Power specific curves

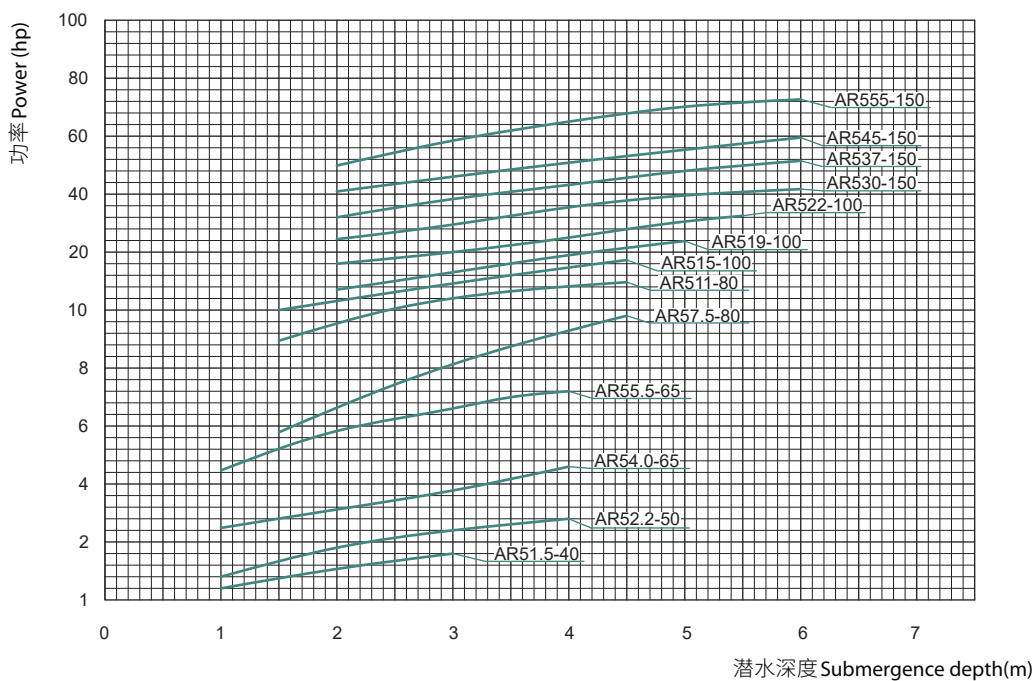

溶氧特性曲线 Oxygen transfer specific curve

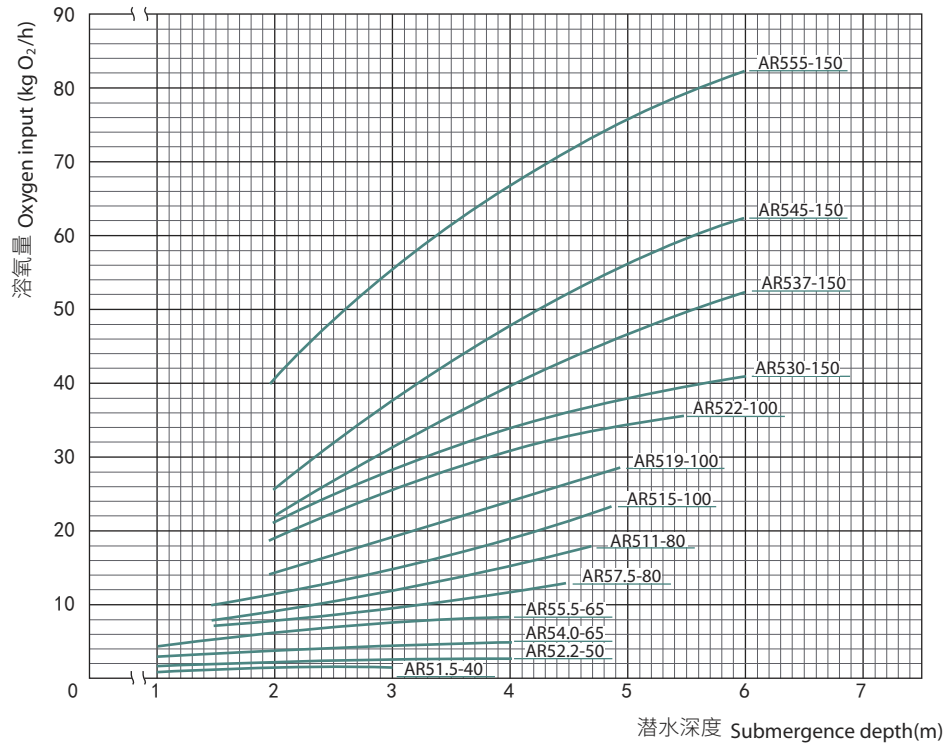

性能参数 Performance parameters

型号 Type	功率 Power		作用范围 Operation range (m)	水深 Min-max water depth (m)	空气吸入管径 Air inlet pipe diameter (mm)	最大吸入空气量 The maximum intake of air (m ³ /h)	溶氧量 Oxygen transfer capacity (kgO ₂ /h)	重量 Weight (kg)
	hp	kW						
AR51.5-40	2	1.5	1.0-2.0	1.0-3.0	40	40	2-1	135
AR52.2-50	3	2.2	2.5-5.0	1.0-4.0	50	60	3-2	147
AR54.0-65	5.5	4	3.0-6.0	1.0-4.0	65	90	5-3	160
AR55.5-65	7.5	5.5	3.5-7.0	1.0-4.0	65	150	9-5	315
AR57.5-80	10	7.5	4.5-9.0	1.5-4.5	80	170	13-7	320
AR511-80	15	11	5.0-10.0	1.5-4.5	80	260	18-8	368
AR515-100	20	15	5.8-11.5	1.5-4.5	100	340	23-10	385
AR519-100	25	18.5	5.9-11.8	2.0-5.0	100	360	29-14	432
AR522-100	30	22	6.0-12.0	2.0-5.5	100	440	36-19	456
AR530-150	40	30	7.3-14.5	2.0-6.0	150	510	41-21	998
AR537-150	50	37	7.5-15.0	2.0-6.0	150	600	52-22	1080
AR545-150	60	45	7.8-15.5	2.0-6.0	150	700	62-25	1155
AR555-150	75	55	8.0-16.0	2.0-6.0	150	780	82-40	1200



外形及安装尺寸 Installation dimensions

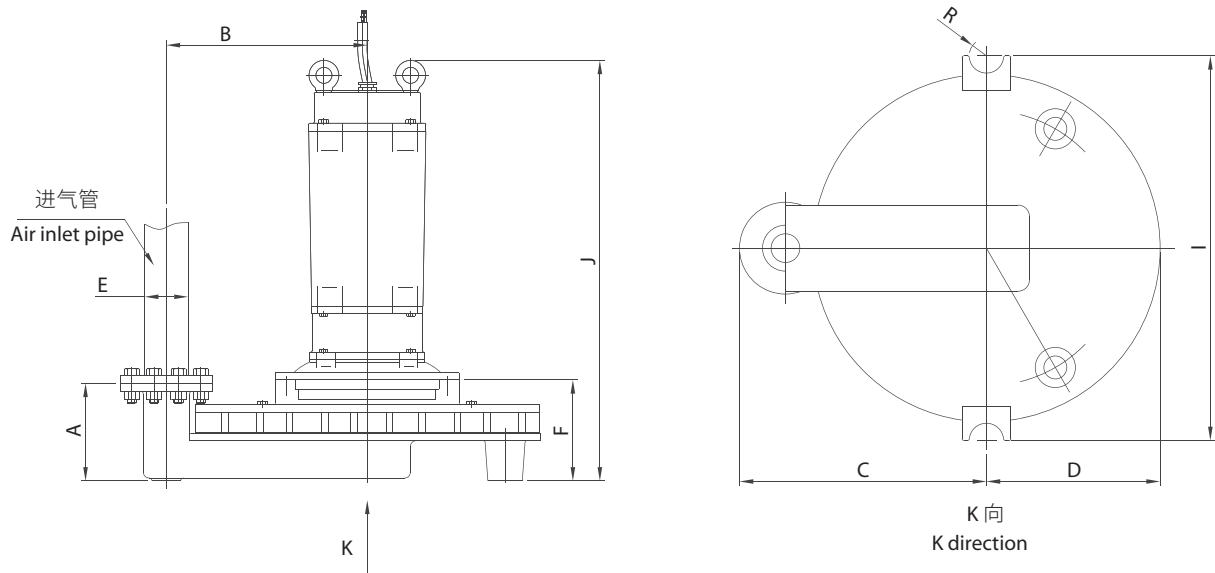

型号 Type	尺寸 Dimensions(mm)								
	A	B	C	D	E	F	I	J	R
AR51.5-40	165	300	365	252.5	40	173	576	617	30
AR52.2-50	170	350	430	302.5	50	176	670	698	30
AR54.0-65	170	350	430	302.5	65	176	670	732	30
AR55.5-65	223	435	540	362.5	65	242	800	855	32.5
AR57.5-80	223	435	540	362.5	80	243	800	855	32.5
AR511-80	223	435	540	362.5	80	248	800	950	32.5
AR515-100	223	435	540	362.5	100	252	800	955	32.5
AR519-100	223	435	540	362.5	100	252	800	1120	32.5
AR522-100	223	435	540	362.5	100	252	800	1120	32.5
AR530-150	338	600	740	475	150	346	1108	1448	39
AR537-150	338	600	740	475	150	367.5	1108	1467.5	39
AR545-150	338	600	740	475	150	367.5	1108	1467.5	39
AR555-150	338	600	740	475	150	367.5	1108	1702.5	39

水池尺寸 Basin dimensions

型号 Type	最大水深(m) Max water depth	形状和尺寸(m) Shape and dimensions		
		圆(直径) Round(Diameter)	正方形 Square	长方形 Rectangular
AR51.5-40	3	3.5	3.1 x 3.1	2.5 x 3.8
AR52.2-50	4	4.8	4.2 x 4.2	3.4 x 5.2
AR54.0-65	4	6.6	5.8 x 5.8	4.8 x 7.1
AR55.5-65	4	8.0	7.1 x 7.1	5.8 x 8.7
AR57.5-80	4.5	9.8	8.7 x 8.7	7.1 x 10.6
AR511-80	4.5	12.5	11.1 x 11.1	9.1 x 13.6
AR515-100	4.5	12.5	11.5 x 11.5	9.1 x 13.6
AR519-100	5	12.5	11.8 x 11.8	9.7 x 14.5
AR522-100	5.5	12.5	12.0 x 12.0	9.7 x 14.5
AR530-150	6	16	14.5 x 14.5	12.5 x 17.0
AR537-150	6	16	15.0 x 15.0	13.0 x 17.5
AR545-150	6	16	15.5 x 15.5	13.0 x 17.5
AR555-150	6	16	16 x 16	13.5 x 18.0

注：为使曝气机能更高效运作，曝气水池中应无过大的固体颗粒和长纤维状物。

Note: To achieve higher efficient operation, oversize particles and long fibers should not in the aeration tank.

安装

为使曝气机有较好的维护，请注意下列：

- 固定装置应在曝气机底部水泥基础上装置(在未注入废水前)。
- 当设计下图桥梁之结构强度时，应考虑绞动及扬起设备。
- 导轨应事先预备并建议使用不锈钢管。
- 进气管应依实际情形予以固定安装。

Installation

For better and easier maintenance of the aerator, following instructions shall be noticed:

- The setter should be fixed on concrete base of the aeration basin (Before the aeration basin was filled with waste water).
- When designing the strength of the bridge (As shown in below Fig.) construction, the warping and the lifting equipment should be considered.
- The guide tubes should be prepared in advance and it is advisable to use stainless steel tubes.
- The air pipes should be fixed if necessary depending upon the actual condition.

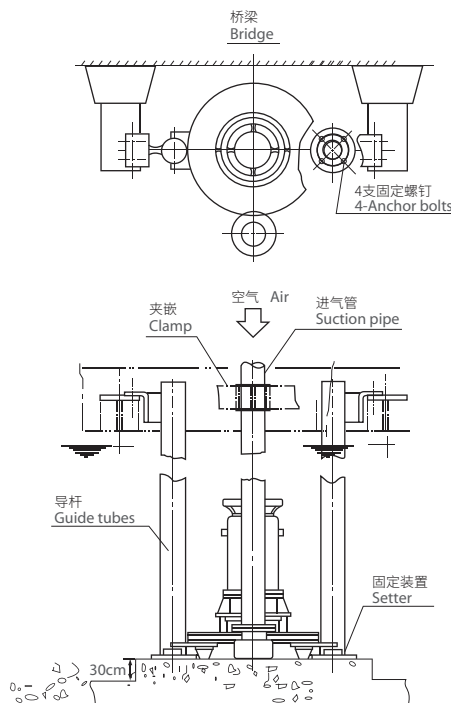

如蒙洽询请指示下列各项

For further details, please fulfill the chart below

客户 _____ 承办人员 _____
 Customer _____ Undertaker _____

工程名称 _____ 工程地点 _____
 Name of project _____ Address of project _____

电话 _____ 传真 _____
 Telephone _____ Fax _____

当地状况 Local condition	海拔 (m) Elevation		最高相对湿度 (%) Max relative humidity	
	当地大气压力 (MPa) Local atmospheric pressure		最高气温 (°C) Max air temperature	
污水情况 Water condition	污水类型 Wastewater type		处理工艺 Treatment process	
	* 曝气时间 (H/day) Aeration time		日处理量 (m ³ /d) Waste water daily volume	
		曝气池进水 Aeration tank Inlet	曝气池出水 Aeration tank effluent	
	COD (mg/l)			
	BOD (mg/l)			
	NH ₃ -N (mg/l)			
	pH			
	温度 (°C) Temperature			
	其他 Others			
*曝气机参数 JA's parameters	使用场所 Use location	<input type="checkbox"/> 调节池 Regulating reservoir <input type="checkbox"/> 曝气池 Aeration tank <input type="checkbox"/> 其他 Others		
	空气量 (m ³ /min) Air capacity		溶氧量 (kgO ₂ /h) Dissolved oxygen	
	水深 (m) Water depth		其他 Others	
*水池尺寸 Tank's dimensions	方形 Rectangle or square (m)	长 Length		
		宽 Width		
		高 Height		
	圆形 Circle (m)	直径 Diameter		
		高 Height		
其他 Others				
其它要求 Other requirements				

备注: 1. 以上资料请尽可能完整填写。
 2. 项目前加注“*”者, 请务必填写。

Notes: 1. Please fill in the parameter lists as complete as possible.
 2. The item with "*" must be filled.

本型录内容如有变更, 恕不另行通知。
 We reserve the right to change content without notice.

川源(中国)机械有限公司版权所有 all rights reserved. CY-J9

